

## SERIES 93 AND 95 DIGGERS

**Always operate, inspect and maintain this tool in accordance with American National Standards Institute Safety Code for Portable Air Tools (ANSI B186.1) and any other applicable safety codes and regulations.**

FOR TOP PERFORMANCE AND MAXIMUM DURABILITY OF PARTS, OPERATE THIS TOOL AT 90 psig (6.2 bar/620 kPa) AIR PRESSURE WITH 3/4" (19 mm) AIR SUPPLY HOSE.

### WARNING

Always turn off the air supply and disconnect the air supply hose before installing, removing or adjusting any accessory on this tool, or before performing any maintenance on this tool. Failure to do so could result in injury.

### PREPARATION FOR SERVICE

Pour about 3 cc of clean kerosene into the air inlet and operate the tool for 10 or 15 seconds. Immediately afterward, disconnect the hose and pour about 3 cc of Ingersoll-Rand Lubricant No. 10, light valve oil, or high-speed spindle oil into the air inlet and again operate the tool to lubricate the internal parts cleaned by the kerosene.

### LUBRICATION

Use Ingersoll-Rand Lubricant No. 10, or a good grade, non-gumming, high-speed spindle oil.

We recommend an air line lubricator be used with each tool. Install an Ingersoll-Rand No. 8LUB12 lubricator unit (1/2 pt. capacity) as close to the tool as practical. Adjust the lubricator so there is a slight oil mist in the exhaust. Unless a lubricator is used, lubricate the tool as follows:

**For T-Handle Tools:** At the beginning of the work shift after each eight hours of operation, unscrew the Oiler Plug (33) from the Oiler Body (32) and fill the chamber with the recommended oil.

**For Tools with Trigger Handle:** At the beginning of the work shift and after each two or three hours of operation, pour 3 cc of the recommended oil into the air inlet.

After each 48 hours of operation, or at any time the tool operates sluggishly, flush the tool with kerosene as described in Preparation for Service. Immediately afterward, pour 3 cc of the recommended oil into the air inlet and operate the tool long enough to lubricate the internal parts cleaned by the kerosene.

### CAUTIONS

Keep the Handle Bolt Nuts (16) tight. Check periodically. Install the Buffer (27), Buffer Spacers (28) and Buffer Washers (29) in the order illustrated in the sectional views. Note that tools with a hexagon Nozzle (24) have the Buffer Spacer installed adjacent to the Nozzle while tools with a square Nozzle have the Buffer Spacer installed adjacent to the forward end of the Retaining Sleeve (26).

Install a new 7/8" Hexagon Nozzle beveled end first, counterbored end outward.

Install a new 3/4" Square Nozzle square end first, counterbored end outward.

*(Continued on Page 3.)*

Notice: The use of other than genuine Ingersoll-Rand replacement parts may result in decreased tool performance and increased maintenance, and may invalidate all warranties.

**INGERSOLL-RAND®**  
**PROFESSIONAL TOOLS**

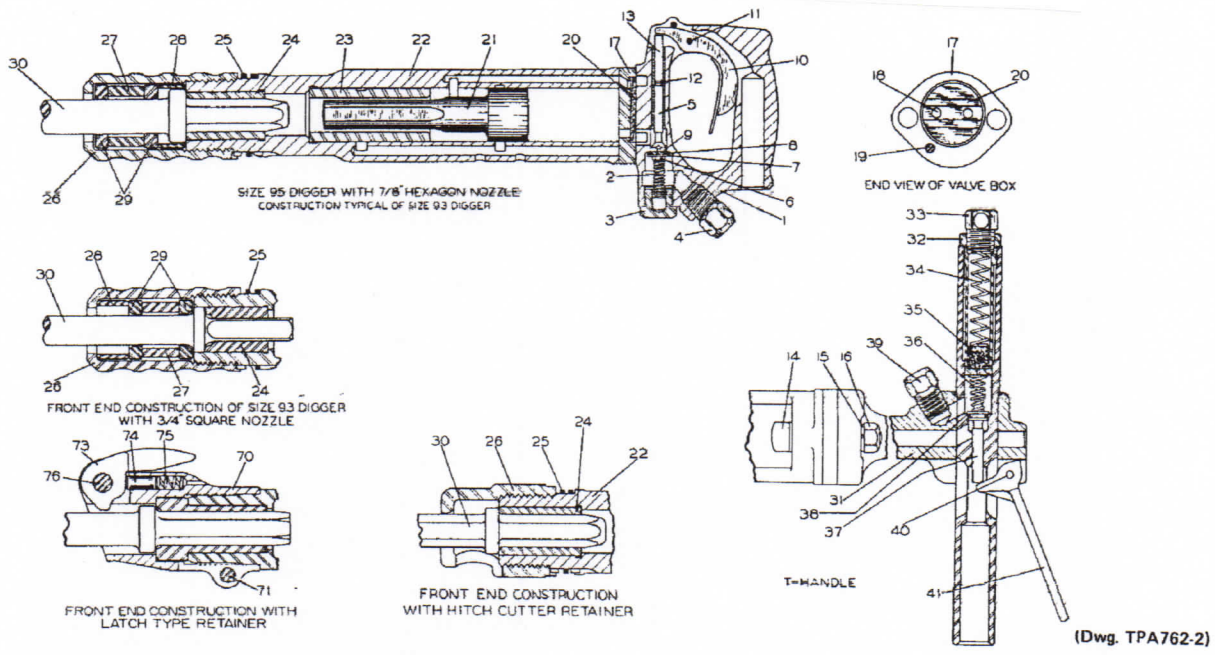

PART NUMBER FOR ORDERING

PART NUMBER FOR ORDERING

1	Inside Trigger Handle Assembly. . . . .	7500-92	• 27	Buffer . . . . .	93H-50
2	Throttle Valve Spring. . . . .	H80-11	• 28	Buffer Spacer. . . . .	93H-31
3	Throttle Valve Cap . . . . .	7500-109	• 29	Buffer Washer (2) for accessories with hex shanks . . . . .	93H-331
4	Inlet Bushing (1/2" pipe to 3/8" pipe). . . . .	H80-82A		for accessories with square shanks. . . . .	93H-431
• 5	Throttle Valve . . . . .	8000-50	30	Accessory (Ingersoll-Rand offers a complete line of Chisels, Flat Picks, Spades, etc. Inquire at nearest Office for types and prices.)	
6	Throttle Valve Face Cap Nut. . . . .	73H-158		T-Handle Assembly. . . . .	93H-A35
7	Throttle Valve Face Cap. . . . .	8000-157	31	Handle Assembly. . . . .	157H-A36
8	Throttle Valve Face. . . . .	8000-159A		Oiler Assembly . . . . .	157H-A72
9	Throttle Valve Face Lock Washer. . . . .	H54U-352	32	Oiler Body . . . . .	157H-72
10	Throttle Lever . . . . .	97MP-18	33	Oiler Plug. . . . .	157H-73
11	Throttle Lever Pin . . . . .	13SR-265	34	Oiler Spring . . . . .	157H-74
12	Throttle Valve Bushing. . . . .	7500-65	35	Oiler Felt . . . . .	157H-71
13	Throttle Valve Plunger. . . . .	7500-64	36	Throttle Valve Spring. . . . .	TAA-418
14	Handle Bolt (2) . . . . .	A-9	• 37	Throttle Valve Assembly. . . . .	159H-53
15	Handle Bolt Lock Washer (2) . . . . .	H80-67	38	Throttle Valve Face . . . . .	PS3-51
16	Handle Bolt Nut (2) . . . . .	H3R-8	39	Inlet Bushing (1/2" to 3/8" pipe). . . . .	H80-82A
17	Valve Box . . . . .		40	Throttle Lever Pin . . . . .	13SR-264
	for Series 93. . . . .	73H-41	• 41	Throttle Lever . . . . .	158H-66
	for Series 95. . . . .	75H-41			
18	Valve Dowel (2) . . . . .	73H-45			
19	Valve Box Dowel. . . . .	73H-21			
20	Valve . . . . .				
	for Series 93. . . . .	730H-40			
	for Series 95. . . . .	33SR-40			
• • 21	Piston . . . . .		†	Fronthead Assembly for accessories with 1-3/8", 1-1/2" or 1-5/8" diameter collar (35, 38 or 41 mm)	
	for Series 93. . . . .	93H-200		for tools with 7/8" hex x 3-1/4"	
	for Series 95. . . . .	95H-200		Nozzle. . . . .	95L-A240
22	Barrel Assembly . . . . .			for tools with 1" hex x 4-1/4"	
	for Series 93 . . . . .		70	Nozzle. . . . .	95L-A340
	with 7/8" hex Nozzle. . . . .	93H-AH100		Fronthead . . . . .	
	with 1" hex Nozzle . . . . .	93H-AH100-1		for tools with 7/8" hex x 3-1/4"	
	with 3/4" Square Nozzle. . . . .	93H-AS100		Nozzle. . . . .	95L-240
	for Series 95 . . . . .			for tools with 1" hex x 4-1/4"	
	with 7/8" hex Nozzle. . . . .	95H-AH100		Nozzle. . . . .	95L-340
	with 1" hex Nozzle . . . . .	95H-AH100-1		Fronthead Pinch Bolt. . . . .	21-342
• 23	Barrel Bushing . . . . .		71	Pinch Bolt Nut (ESNA # 29NE-083 Stop Nut) . . . . .	D02-904
	for Series 93. . . . .	73H-101	*	Retaining Lever. . . . .	95L-341
	for Series 95. . . . .	95H-101		Retaining Lever Plunger . . . . .	73L-245
• 24	Nozzle . . . . .		73	Retaining Lever Plunger Spring . . . . .	95L-246
	7/8" hex . . . . .	73H-86	74	Retaining Lever Pin . . . . .	95L-342
	1" hex. . . . .	93H-186			
	3/4" Square . . . . .	73H-84	75		
• 25	Sleeve Locking Spring . . . . .	97MP-48A	76		
• 26	Retaining Sleeve . . . . .				
	Standard Type . . . . .	93H-22			
	Hitch Cutter Type . . . . .	273H-22			

\* Refer to OVERSIZE PARTS on page 3 before ordering.

\* Not illustrated.

• To keep downtime to a minimum, it is desirable to have on hand certain repair parts. We recommend that you stock one (pair or set) of each part indicated by a bullet (•) for every four tools in service.

† Complete assemblies are interchangeable with discontinued 93L-A140 and 93L-A240; however, component parts differ from those in the previous models and are not interchangeable. New Frontheads are stamped 95L-240 or 95L-340 for positive identification.

### OVERSIZE PARTS

PART NUMBER FOR ORDERING ➔

21	Oversize Piston .010" oversize for Series 93 ..... for Series 95 .....	93H-200-10 95H-200-10
24	Oversize Nozzle 1" Hexagon .001" oversize ..... .002" oversize .....	93H-186-10 93H-186-20

Piston (21): If the barrel bore becomes sufficiently worn to require an oversize Piston, the Barrel (22) must be returned to the factory for regrounding and installation of an oversize Barrel Bushing (23). A reground Barrel is stamped "10" or "20" above the nameplate to respectively indicate .010" or .020" oversize. Use only the corresponding oversize Piston in a stamped Barrel.

A Nozzle (24) whose outside diameter is .001" or .002" oversize can be furnished as a repair part. Do not increase the oversize each time the Nozzle is replaced, but only as the fit warrants it. Do not increase the oversize by more than .001" at any time. The amount of oversize is etched on the Nozzle for easy identification.

### MUFFLER PARTS

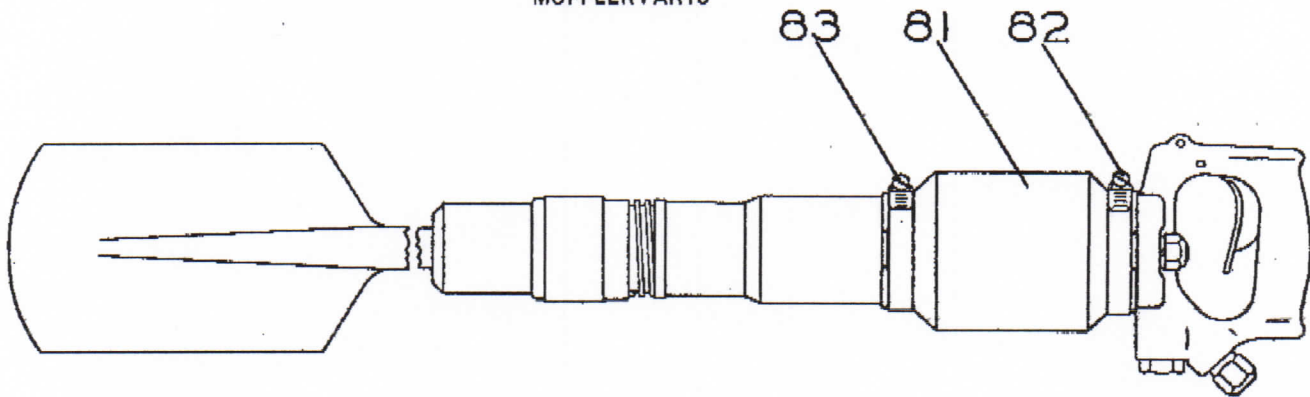

(Dwg. TPD431-1)

PART NUMBER FOR ORDERING

		Series 93	Series 95
	Muffler Kit .....	93H-K674	95H-K674
81	Muffler (2) .....	73H-674	75H-674
82	Large Clamp .....	59H-675	59H-675
83	Small Clamp .....	HHW1-676	MHW1-675



SWIVEL INLET PARTS

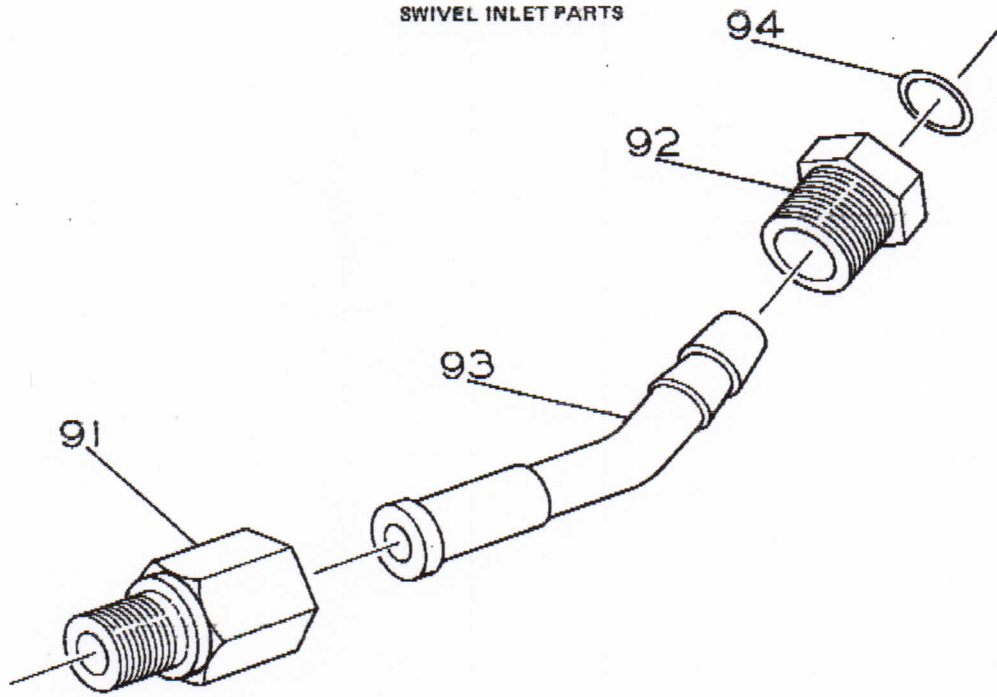

(Dwg. TPD931)

PART NUMBER FOR ORDERING

91	Swivel Inlet Assembly .....	HH1-A165
92	Reducing Bushing .....	HH1-165
93	Swivel Inlet Sleeve .....	HH1-166
93	Swivel Inlet Nipple .....	HH1-167
94	O-ring .....	R00BR-210

MAINTENANCE TOOLS

TOOL NUMBER FOR ORDERING	TOOL NAME FOR ORDERING	OPERATION
MT2-27	Socket Wrench .....	Removing or applying the Handle Bolt Nuts (16).
57H-119	Nozzle Ejecting Arbor .....	Removing the Nozzle (24) from the Barrel (22).